



Abbey House, Charter Street, Leicester. LE13UD
Tel: 0116 242 5425. Fax: 0116 242 5555
Email: sales@flowmech.co.uk www.flowmech.co.uk

Installation, Operation and Maintenance Instructions for a CAT 5 –TKS Invertor driven single pump set with break tank.

Please fulfil all listed requirements prior to and during installation and operation of all equipment to prevent invalidation of any warranty given.





General Installation

Site Location

During off loading and positioning of the unit, care must be taken not to lift with the pipe work or any electrical equipment.

The unit location should be undercover, dry and freely ventilated. Protection from frost must be ensured.

Reasonable access to all parts of the set and adequate service work space must be provided.

The site base should be firm and level.

All system pipework should be aligned and self supporting preventing any strain on the unit.

On units without isolating valves, these together with unions should be fitted to enable the removal of the pump should a replacement be necessary. We always recommend a union or flange between our manifolds and site system pipework.

Water Supply

The stored water should be clean and free from any foreign materials. There should be nothing suspended or dissolved to block or wear the pump internal components.

The water storage tank should provide the pump with a fully flooded suction (with the exception of self priming units) at all times irrespective of water level within the tank.

A ball float valve is supplied in the tank which should be connected to the mains supply via a union and a stop cock for isolation.

Electrical

Applications

The Tecknospeed Booster consists of a three phase electrical pump, the Tecknospeed single phase converter and the electronic pressure transmitter (also known as pressure sensor).

The tecknospeed single phase converter is suitable for the control of a three phase electric pump according to the conditions described in this manual and the supply voltage / frequency specified in the rating plate.

(Please wire this unit with a 240v/1ph/50hz supply)





The converter controls the operation of the pump in order to ensure a constant delivery pressure based on the signal received from the electronic pressure transmitter. The tekno speed system can be used for domestic water supply, irrigation and pressure boosting applications.

Note to Electrician

DO NOT PUT POWER TO THESE UNITS UNTIL THEY HAVE BEEN FILLED WITH WATER AND PRIMED. The pumps will start automatically on power being applied.

Make sure that the type of power source, the supply voltage and frequency match the ratings of the Teknospeed shown in the rating plate. Provide suitable general protection against short circuits on the electrical power line.

WARNING: although the Teknospeed has single phase power supply, the pumps motor is always a three phase motor connected to 230 volts delta. The missing phases are created by the converter.

Before proceeding with any maintenance, make sure that all the connections (even those that are potential free) are voltage free. Always disconnect the Teknospeed converter from the power supply before carrying out any operations on the systems electrical or mechanical components. After disconnection from the power source, wait at least 3 minutes before carrying out any work on the Teknospeed to allow the condensers in the internal circuit to discharge.

Differential magneto thermal switch

If local regulations require the installation of differential magnetic thermal switch make sure it is suitable for the characteristic curve for unidirectional alternate and pulsating DC fault currents (type A or C)

The supply should be brought to the set with suitable trunking or armoured cable, terminating in the final metre in a flexible conduit or flex to avoid any stress or fatigue.

All supply cables should be sized to accommodate any long run voltage drop, when checked at the unit the voltage should match that on the specification sheet or motor plate.

A neutral supply is required for all 240 volt sets.

It is recommended that a fused isolator is fitted locally to the unit (if not fitted to unit).

Supply fuses should be rated to accommodate the pump motor.





Where MCB units are fitted, these provide cable protection to the technospeed units. The invertors provide motor protection via over temp, over current / voltage protection.

The TEKNOSPEED converter is equipped with an input filter according to the EMC directive.

Motor Overload Protection

The TEKNOSPEED converter has an incorporated overload protection which guarantees absolute protection when it is connected to motors featuring the same nominal protection as that of the converter. For lower power motors an auxiliary protection is used.

Motor Over temperature Protection (PTC)

Some models may feature an extra protection (thermistor) in addition to the overload protection incorporated in the converter. The thermistor (PTC) is attached to the base of the terminal board and connected through cables and mini-fasteners. The corresponding dip-switch will be in the PTC Y position.

Converter over temperature protection

The Teknospeed converter has an incorporated over temperature protection

It is recommended that a fused isolator is fitted locally to the unit

Supply fuses should be rated to accommodate the pump motor.

If using an MCB fit a "D" rated unit

Protection against dry running (float switch)

The TEKNOSPEED converter can be connected to an external device for protection against pump dry Running. The most conventional method consists in the use of a float switch installed in the suction tank.

To connect the cable of the external device you must remove the converter's radiator using a no. 5 Allen wrench (maximum torque 6 Nm). Turn the radiator upside down, paying attention to the connections with the removable terminal board. The terminal board may have to be extracted. Replace an M 16 x 1.5 plug with one of the cable glands supplied, install the float switch cable and connect it to the terminals corresponding to LOW 1 and LOW 2 (suitable for 0.5-1 mm² conductors). Screw down the cable fastening plate and tighten the cable gland to secure the cable.

If you are not using a float switch, the two terminals must be connected with a jumper. (This is normally fitted at works)





External Enable Device

You can connect a volt free relay contact instead of the float switch. This external device can be used to enable or disable the system. We recommend using a shielded cable. The stripping of the cable should allow the shielding to be in contact with the cable fastening plate.

Alarm Relay

The TEKNOSPEED converter has a contact that can be used to obtain an external shutdown or malfunction signal.

This contact is closed when the pump is not running due to one of the following causes :

No voltage

Motor overload

Motor over temperature

Converter over temperature

Probe faulty or disconnected

Lack of water on suction side

To connect the cable you must first take the radiator off the converter using a no. 5 Allen wrench (maximum torque 6 Nm). Turn the radiator upside down, paying attention to the connections with the removable terminal board.

The terminal board may have to be extracted. Replace an M 16 x 1.5 plug with one of the cable glands supplied. Lay the cable and connect it to the terminals corresponding to COM and NO). Screw down the cable fastening plate and tighten the cable gland to secure the cable.

We recommend using a shielded cable. The stripping of the cable should allow the shielding to be in contact with the cable fastening plate.

The TEKNOSPEED converter has an incorporated overtemperature protection. Do not connect any wires to the COM, TX, RX terminals of the serial interface.

All equipment should be earthed.

All electrical work should be performed by a competent electrician.





Regulation Dip switches

The Teknospeed converter is equipped with a series of microswitches (dip switches) that determine its operating cycle. Do not modify the factory setting: you could damage the converter or the system on which it is installed.

Wiring Diagram - Single Phase

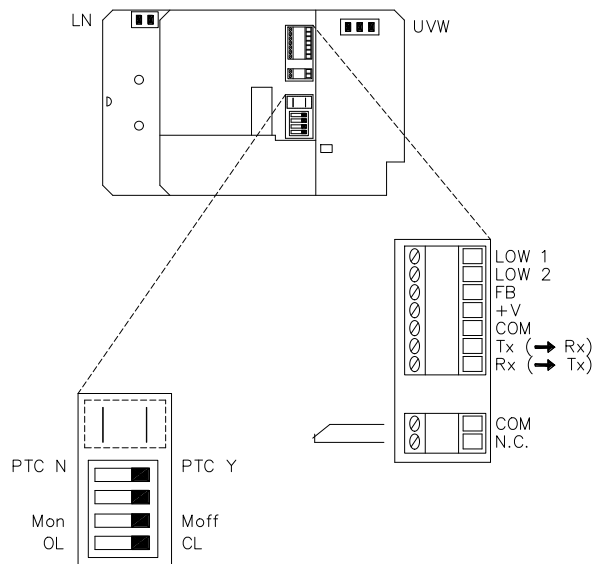

1. Connection to external device for dry running protection
2. Connection to external transmitter
3. Serial interface connection
4. Connection to alarm relay (240V, 1 a Max)
5. Connection to motor over temperature protection
6. Operating cycle adjustment dip switch

LOW1 and LOW2
COM and N.C

Float Switch (isolate 3rd switch not used)
Volt Free Contact for pump failure

All equipment should be earthed.

All electrical work should be performed by a competent electrician.





Working Conditions

Do not use the product in environments where corrosive and / or flammable powders, acids, gases, etc are present

Do not use the electric pump to handle dangerous or flammable liquids

- Ambient temperature: +0 degrees cent. To + 40 degrees Cent.
- Maximum relative humidity: 50% at + 40 degree Cent provided no condensation occurs
- Protection class: IP55 (if installed on motors with at least IP55 protection)
- Maximum operating pressure: 10 bar
- Temperature of pumped liquid: +1 degrees C + 40 degrees Cent
- Nature of pumped liquid: water containing no aggressive substances or suspended solids
- Maximum rated power of electric pump connected to the converter: 1.1 kW
- Converter supply voltage: 1 x 230V plus/minus 10% 50/60Hz
- Converter output voltage (corresponding to the motor supply voltage): 3 x 230V plus/minus 10% 3050Hz (these values vary according to the converters voltage/frequency curve)
- Converters rated input current: 6.8 A
- Converters rated output current: 4.6 A

Start Up

Priming

After flooding the suction line the pumps should be primed and vented. On vertical multistage type pumps these should have the individual vent plugs loosened to allow air purging and water flow to each priming point, this may have to be repeated if poor pump performance is experienced due to trapped air pockets.

On certain horizontal end suction pumps these too may have a vent plug, but if not fitted air should be allowed to evacuate via a suitable point of the discharge pipework, e.g. a drain cock, tap etc.

NEVER RUN ANY PUMPS EVEN TO CHECK ROTATION BEFORE COMPLETE PRIMING IS ACHIEVED.

Run the pump to check rotation to correspond with the pump casing arrows. If incorrect contact the service dept. After checking that all valves with the exception of the final discharge are open. Switch on the local isolating switch. Briefly run the pump to check rotation, if correct continue to run the unit at which point the final discharge valve should be opened slightly to vent any pipework air and then closed again allowing the pump to fill the accumulator, finally switching off the pump via the inverter controller.





Open the main valve slowly filling the system taking care not to overload the pump at this point and as the system pressure rises open the valve fully to leave the system operational.

All units are wet tested and set before despatch.

The Teknospeed system comes with a factory setting that enables it to be used straight away.

To modify the pressure based on the actual system requirements proceed as follows:

Increasing the pressure value

Make sure that the system is pressurized, no taps are open and the pump is off. If there are any open taps you can close the on-off valve located on the pump's delivery side.

Unscrew the cap that protects the adjusting screw.

Open the discharge valve so you get the smallest flow possible while you make the adjustments

Turn the adjusting screw slowly to the right using a screwdriver.

The adjusting screw has a limited travel, less than one turn, between the minimum value (0 bar) and the maximum value (10 bar). **Do not force it beyond the limits** as you could damage the adjusting screw.

Read the pressure value on the gauge and keep turning the adjusting screw until the gauge pointer reaches the desired value.

Make sure that the pressure has stabilized at the desired value.

If necessary, make slight adjustments by turning the adjusting screw to the right or left.

Close the final valve and replace the protective cap over the adjustment screw.

Lowering the pressure

Operate as above, when the pump is running turn the adjustment anti-clockwise to reduce the pressure, allow the pressure to escape from the open valve and the pressure to stabilize before adjusting further. After final adjustment replace the protective cap.

After any change in pressure the vessel air charge must be changed also to 0.8 bar below the pump pressure.

The vessel air can only be adjusted after the pump is turned off and all water pressure is reduced to zero, adjust the air via the Schrader valve on top of the vessel.





Indicator Lights

On the adhesive plate attached to the top of the radiator there are three LED's with the following functions:

Steady Green Light	Power	Indicates that the Teknospeed is powered
Steady Yellow Light	Run	Indicates that the pump is running
Flashing Red Light	Alarm	Indicates that an alarm is triggered

If an alarm is triggered, the red light will flash more or less rapidly depending on what has caused the system to shut down. Except for lack of water on the suction side, in all other cases the system will automatically start again after 20 seconds. If the cause of the malfunction persists, after three attempts to restart the system will definitively shut down except in case of lack of water on the suction side.

If the system is powered the green (power) light is on.

When the pump is running the yellow (Run) light is on.

If there is a shutdown or malfunction the red (Alarm) light comes on.

Refer to Flow Mech Products for any adjustments and/ or maintenance operations. Do not attempt to change the settings or open the control system.

Extra Controls

On units fitted with low level float switches (or float switches supplied loose) these should be wired to low water connections as shown in the wiring diagram.

Should a low level condition occur this will stop all pumps until the water level resets the switch.

Maintenance

Maintenance operations must be performed by qualified personnel.

Before carrying out any maintenance operations, make sure that all the connections even those that are potential free, are voltage free.

Always disconnect the Teknospeed converter from the power supply before carrying out any operations on the systems mechanical or electrical components.

After disconnection from the power source, wait at least 1 minute before carrying out any work on tekno speed to allow the condensers in the internal circuit to discharge.

Booster sets require very little general maintenance, listed below are quarterly and yearly check schedules.





WARNING!!

Although the Teknospeed has a single phase power supply, the pumps motor is always a three phase motor connected to 230V. The missing phases are created by the converter.

Booster sets require very little general maintenance, listed below are quarterly and yearly check schedules.

Quarterly

The hydraulic accumulator should have its internal air charge checked and adjusted to the correct pressure using a foot pump or oil free compressor. See vessel label for pressure required. It must be stressed that this is only performed after switching off the unit and releasing all the pressure from the set.

Failure to successfully reinflate the air charge, or if water is found to be present at the schrader valve would point to a ruptured vessel membrane, this would require immediate replacement.

The whole unit should be observed for any leaks, particularly the pump shaft seals and the valve glands. If found please contact our service department for assistance.

The pump should be noted for any deviations to the smooth running and performance, again please contact our service department for any assistance required.

If the unit has not been operational for a long period the pump should be vented as described in the start up information. If not in use during the winter period and there is any chance of freezing, drain the pump and pipework and cover with suitable frost protection covering. Ensure full venting before start up.

Yearly

All quarterly checks are to be performed.

The pump should have a full load current, and windings test to ascertain pump motor condition.

The hydrovar should be checked and adjustable is required.

The non-return valve should have a visual and audible inspection for general wear and sealing.

All electrical cables are to be checked for cuts or chaffing and to be replaced as necessary (After unit isolation).

It is recommended that all yearly checks are carried out by our engineers and service contracts are available on request.





Troubleshooting

Operation Signals

Green Light (Power)	Off	No Power	0
Green Light (Power)	On Steady	Power	0
Yellow Light (Run)	Off	Pump Off	0
Yellow Light (Run)	On Steady	Pump Running	0

These basic signals are integrated by the alarm signals. Therefore there could be combinations of signals such as green light on (power), yellow light off (pump off) and flashing red light (alarm).

Alarm Signals

If an alarm is triggered the red light flashes more or less rapidly (flashing – pause – flashing) depending on the cause of the system shutdown.

	Sequence of Flashes
--	---------------------

Red Light (Alarm)	Off	No Malfunction	No Flashes
Red Light (Alarm)	Flashing	Over current Shutdown	☼ x 2 and ☼ x 2
Red Light (Alarm)	Flashing	Converter Over Temperature Shutdown	☼ x 3 and ☼ x 3
Red Light (Alarm)	Flashing	Motor Over Temperature Shutdown	☼ x 4 and ☼ x 4
Red Light (Alarm)	Flashing	Shutdown Caused by Lack of Water on Suction Side Or shutdown Caused By Open External Switch Contact	☼ x 5 and ☼ x 5
Red Light (Alarm)	Flashing	No Signal From Transmitter Shutdown	☼ x 6 and ☼ x 6
Red Light (Alarm)	Flashing	Low Voltage (under voltage) Shutdown	☼ x 7 and ☼ x 7
Red Light (Alarm)	Flashing	Problems at serial output (for 2 pump units)	☼ x 8 and ☼ x 8

Be careful when servicing the system as it could restart automatically

Shutdown caused by lack of water on suction side

If the system shuts down because there is not enough water on the suction side, it will restart automatically if the external device re enables its operation.

Shutdown caused by other problems except for lack of water on suction side

In all these cases the system restarts automatically after 20 seconds. If the cause of the malfunction persists, the system will shut down definitively after three attempts to start.





To reset the system, disconnect the power supply for at least one minute. If 10 minutes elapse after an alarm without any malfunctions occurring, the alarm counter is reset and three new attempts are possible.

If two or more alarms are triggered simultaneously (eg due to motor overtemperatures and lack of water), only the first malfunction signal received by the control board is signalled.

WARNING:

The converter does not have a non-erasable alarm log, we therefore recommend that you observe the flashing frequency carefully before disconnecting the power supply to the Teknospeed.

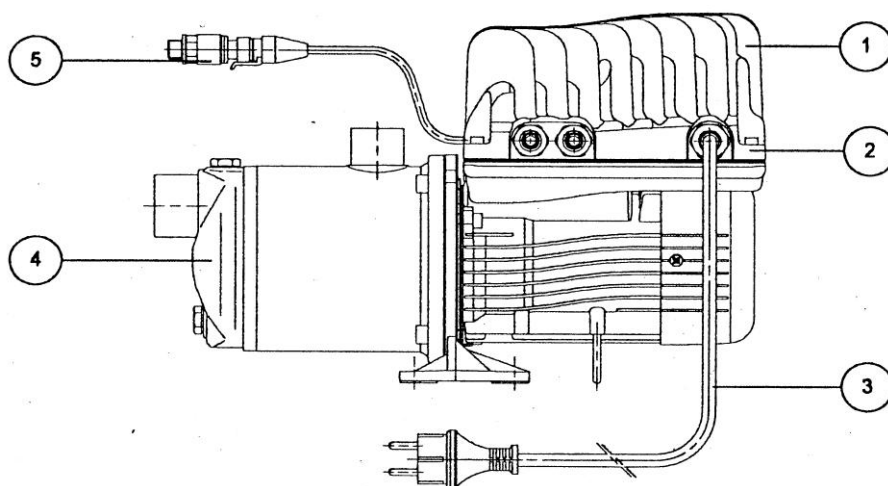

1. Radiator (incorporates the electronic control and command board)
2. Base
3. Cable and plug
4. Electric pump
5. Pressure transmitter

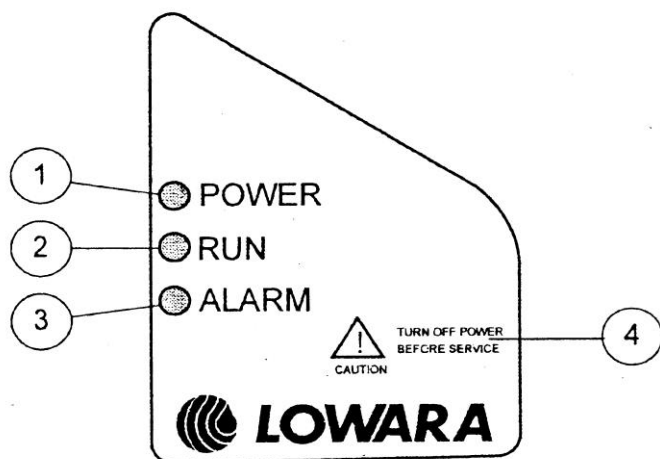

1. Power on indicator
2. Pump running indicator light
3. Malfunction indicator light
4. Warnings



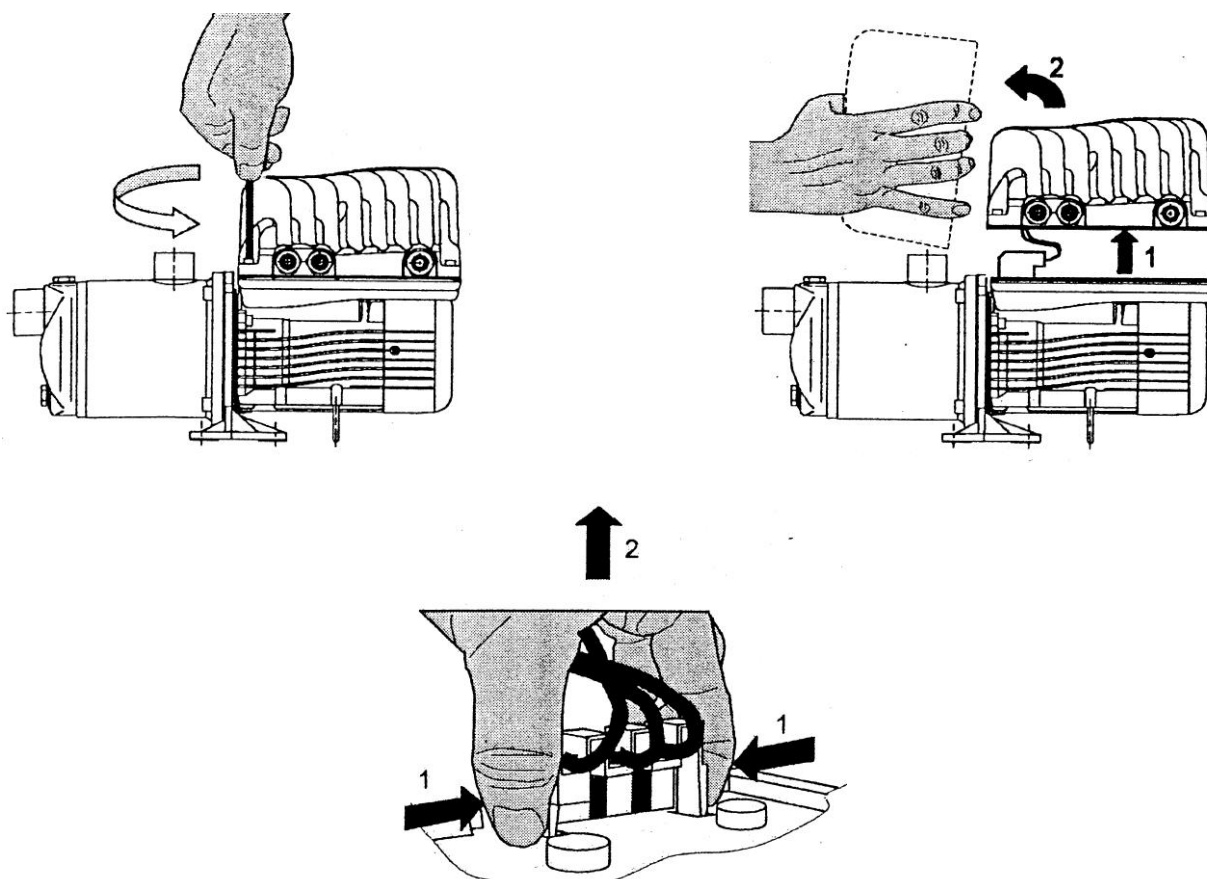

Teknospeed converter opening sequence

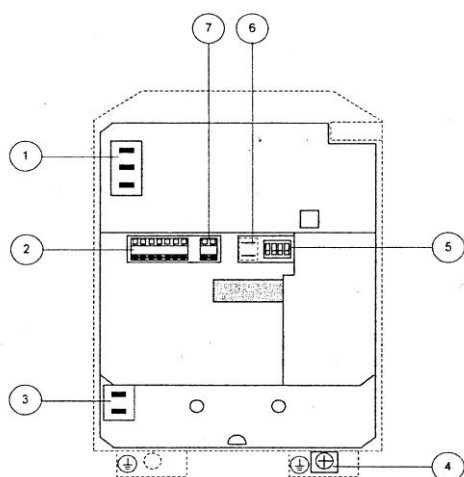

1. 6.35mm Faston male connector for motor terminal board cables
2. Terminal board for transmitter, float switch, serial interface (IN/OUT)
3. 6.35mm Faston male connector for phase and neutral (power cord)
4. Ground screw for power cord
5. Operating cycle adjustment dip switch
6. 2.8mm Faston male connectors for thermistor
7. Terminal board for malfunction signals (OUT)

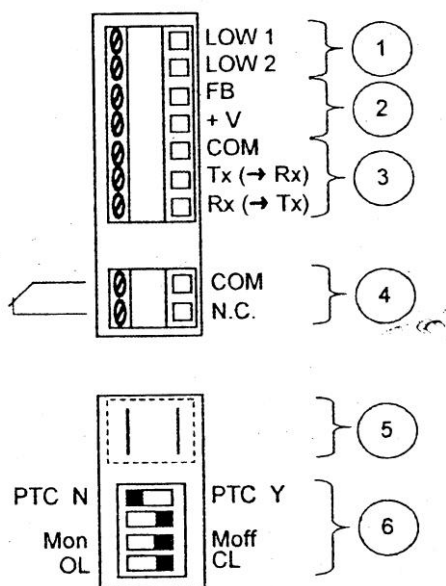

1. Connection to external device for dry running protection
2. Connection to external transmitter
3. Serial interface connection
4. Connection to alarm relay
5. Connection to motor overtemperature protection
6. Operating cycle adjustment dip-switch

