

Operations and maintenance of Fluid Control Booster Sets

FC - Range

Please fulfil all listed requirements prior to and during installation and operation of all equipment to prevent invalidation of any warranty given.

Description of Equipment

The "FC" range of single pump booster sets are designed for small water supply systems feeding taps and solenoids in homes garages, car washers etc.

Limitations

- A. These units are unsuitable for use outside the temperature ranges of +4°C and +50°C (ambient) and 60°C (pumped fluid).
- B. These units should not be installed on systems containing:
 - 1. Expansion vessels of any kind
 - 2. Cisterns operated by float valves ie toilet cisterns or water storage tanks with float operated valves as these confuse the pump control unit.
- C. Max Capacity 2.7 L/S
- D. Max Pressure 10 Bar
- E. Maximum Amps 10 amps FLC

Description of Pump Control Unit

Fig A

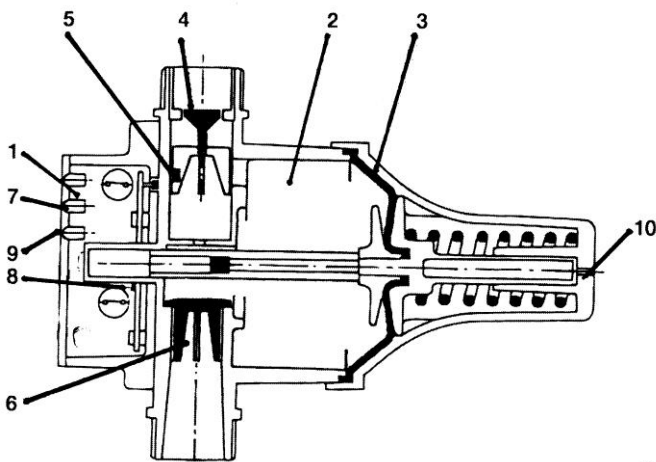
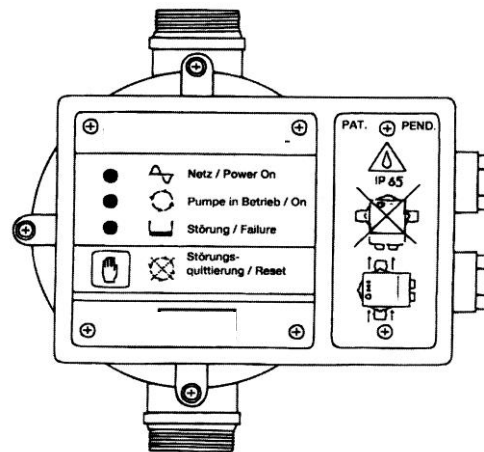

Fig B



With the unit up to system pressure, all taps closed and the power supply on the green LED is on (item 1). The unit contains a small buffer space filled with water (item 2) which is varied by use of a spring tensioned diaphragm (item 3). If an outlet tap in the system is opened water will flow out of the small buffer space into the discharge pipe lifting the float (item 4). The magnet attached to the float is moved out of position thus actuating and opening a magnetic switch (item 5) the pump will start and displace water via a non return valve (item 6) into the pipe work system and the small buffer space. The yellow diode (item 7) indicate normal pump operation.

If the taps close or the water draw off stops the buffer space and the pipe system will be pressurized to the spring pressure cut off point, this resulting in the float dropping due to zero flow switching off the pump. If after 6 seconds the pump fails to deliver water through the controller despite operation command (due to lack of water, pump failure etc) the buffer pressure will fall off and the spring will push the diaphragm to minimum volume. A magnet at the guide/switch rod of the diaphragm will be moved into the vicinity of the magnetic switch, opening the switch contacts (item 8) and stopping the pump after 8 seconds delay and switching the red LED (item 9) on, this action also acts as dry running protection.

The safety valve (item 10) prevents excessive pressure within the unit should the diaphragm fail.

NEVER ADJUST OR REMOVE THE SAFETY VALVE.

The switch unit contains the electronic components as well as the terminal connections for both power supply and pump motor.

The signal / operating elements on the cover are (fig B)

Green LED	Mains power on, the pump is ready to run.
Yellow LED	Pump running.
Red LED	Unit failure or lack of water.
Reset Button	After rectification of a fault the reset button must be kept pushed until the system is fully pressurised, this is also valid for start up where the pump takes longer than 6 seconds to provide water on first operation.

General Installation

Site Location

During off loading and positioning of the booster set care must be taken only to lift via the pump.

The unit location should be undercover, dry and freely ventilated. Protection from frost must be ensured.

Provision should be made for the disposal of system drained water.

Reasonable access to all parts of the set and adequate service work space must be provided. Provision for lifting equipment is recommended for units incorporating large pumps.

The floor base should be firm and level in all directions, and points are provided for floor fixing if desired. Isolation of the set if required should be by optional ant vibration stand together with pipework flexibles.

All system pipework should be aligned and self supporting preventing any strain or distortion within the unit.

Water Supply

The stored water should be clean and free from any foreign materials. There should be nothing suspended or dissolved to block or wear the pump internal components.

Electrical

The set is equipped with a 2.5m long connecting cable to be fitted with a suitable plug or wired into a fused isolator. A suitable fused supply should be used. All equipment should be earthed. This is a single phase 240V / 50 Hz unit. All electrical works to be carried out by qualified personnel, complying with all current UK regulations.

Operation

The Fluid Controller (F.C.) is designed to start the pump when the system pressure falls, upon start up the unit continues to pump until the demand stops at which point the pump is stopped. Should there be a lack of water the internal float switch will disable the pump, if this happens check the water tank has refilled and press and hold the red button until the system has re-pressurised.

The F.C. has three indicator lamps:

Green:	Mains power on, pump ready to run
Yellow:	Pump Run
Red:	Fault

Start – Up

Ensure water is flowing into the water tank.

Open suction isolation valve.

Vent the pump via the hexagon head vent screw mounted on top of the pump until water is released, tighten nut.

Open discharge valve ¼ turn

Turn on power and allow pump to start.

Open discharge valve to half open and provide water to system. When fully up to pressure fully open discharge valve.

Maintenance

The fluid controller is maintenance free.

The pump should be checked for leaks or bearing noise.

Please contact Flow Mech Products for any repairs / service requirements.
